

# STEER-BY WIRE SIMULATION MODEL

eng. Brabec P.<sup>1</sup>, doc. eng. Malý M.<sup>2</sup>, eng. Voženilek R.<sup>3</sup>,  
 Faculty of Mechanical Engineering<sup>1,2,3</sup> – Technical University of Liberec, Czech Republic  
 E-mail: pavel.brabec@tul.cz; E-mail: miroslav.maly@tul.cz; E-mail: robert.vozenilek@tul.cz

**Abstract:** This paper summarizes the results obtained from the simulation of a mathematical model of a vehicle with a steer-by-wire system (an electrohydraulic system) while cornering. The simulation was carried out in the MATLAB – Simulink software.

**KEYWORDS:** STEER-BY-WIRE, 4WS, DRIVE SIMULATION

## 1. Introduction

The safe and stable control of a vehicle undoubtedly belongs to one of the most important requirements that relate to the vehicle's design and operation. Consequently, in the near future, so called steer-by wire systems could become the next stage in the control system development. The term itself could be simply translated as „wire aided steering“, i.e. there is no rigid link between the controller (the steering wheel) and the steering rod. The system is already in common use in aviation engineering and various prototype vehicles. For the time being, it is legislation which prevents the system from being used in mass production. A number of new, modern vehicles presented by car makers at important car shows definitely show how topical the issue is.

could create conditions for optimization of the kinetic bonds and consequently improve the 4WS system (Four-Wheel-Steering)'s directional control. The new design and the adaptive control could considerably improve the vehicle's handling characteristics – a successful solution would result in better manoeuvrability and driving directional stability.

The electromechanical steer-by-wire system to control the rear axle wheels was presented, for example, by Continental Automotive Systems in the GCC system.

### Conventional steering system

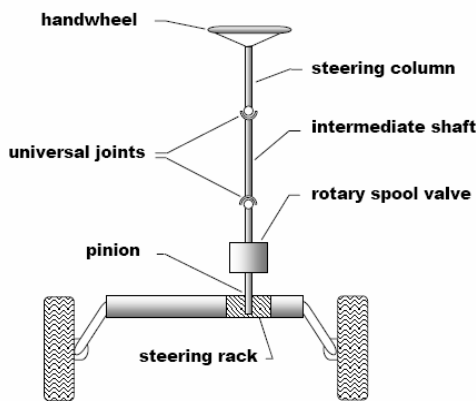

### Steer-by-wire system

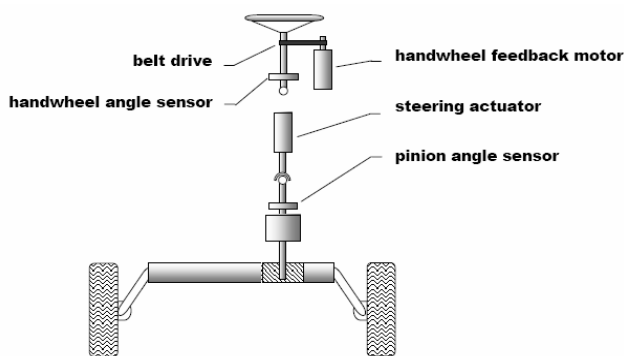

Fig: Conventional Steering System and Steer-by-wire System Diagrams [1].

Releasing the rigid link between the steering wheel and wheels offers several possibilities of solving the vehicle's higher active safety in combination with other electronic systems which have already been applied to vehicles. The combination of the steer-by-wire system with ESP systems (electronic stability program) and the adaptive cruise control (ACC) which monitor the situation in front of the vehicle as well as at its sides and rear seems to be very practical. Releasing the „rigid“ link of the vehicles' front wheels

### CITROËN C5 BY WIRE



Fig.: Citroën C5 Steer-by-Wire System.

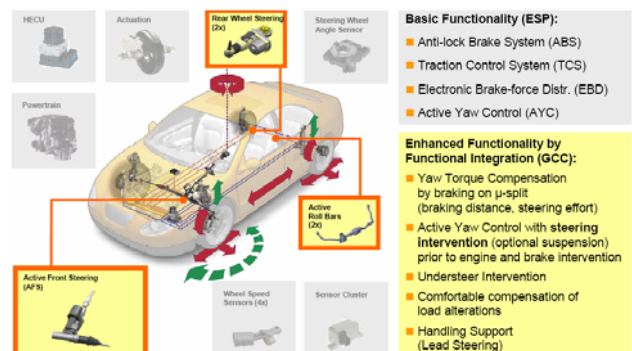

Fig.: GCC System (Global Chassis Control) – Components and Functions [9].

An experimental laboratory establishment for measuring and optimizing the steer-by-wire electrohydraulic systems is being developed in our center. An electromechanical system installation is being considered thereafter.

The first testing equipment, which is being implemented at the moment, was developed to test the system at zero speed – the situation which occurs at parking. The testing equipment is made of aluminum sections enabling the equipment to be quickly adapted to various vehicle's axles and tyres. An exchangeable mat located under a tyre enables the system behaviour simulation for various surfaces having different coefficient of adhesion. The sliding way with assistance of an hydraulic jack under a tyre allows a change in axle load for example in accordance with vehicle occupancy. A force sensor will be positioned between the jack and the mat to monitor the load adjustment.



Fig.: Zero angular speed testing – view of the testing equipment.

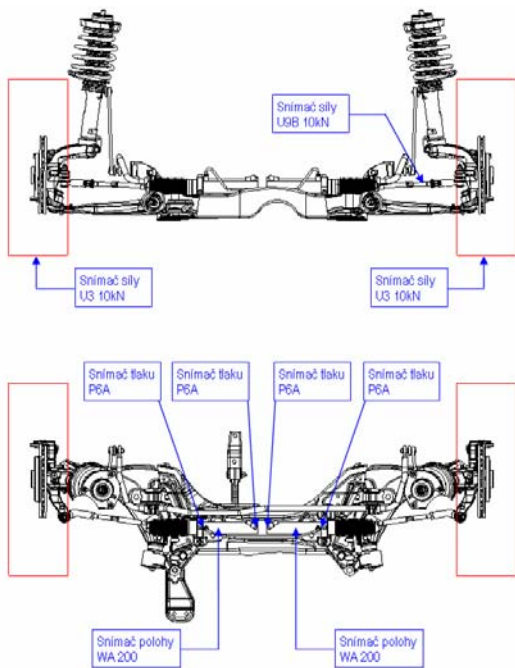

Fig.: Stand for angular speed testing – position of sensors.

## 2. Simulation Model Description

An electrohydraulic system is being developed concurrently with work on the experimental laboratory establishment. A mathematical description of the whole steer-by-wire system represents a complicated task. The simulation requires suitable simplifications to be used. An alternative simplified model was created in the MATLAB – Simulink environment. The simulation model created by us consisted of several submodels.

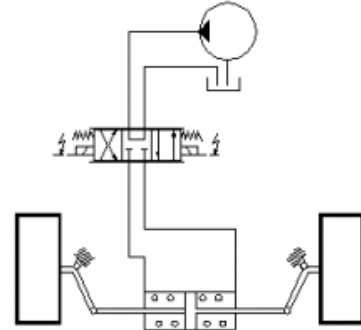

Fig.: Simulated electrohydraulic steer-by-wire system.

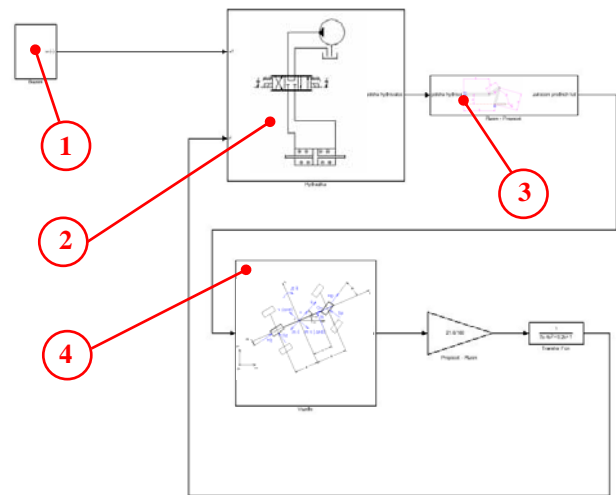

Fig.: View of a complete model with individual submodels: 1. excitation (value of voltage signal [%]), 2. hydraulic circuit, 3. steering system (front axle wheel angle determined from the piston rod extension), 4. vehicle model (driving simulation – determination of vehicles's trajectory and dynamic forces acting on the vehicle).

### 2.1. Hydraulic Circuit – (see [5])

This subsystem consisted of other separately simulated partial subsystems ( a valve for continuous regulation of flow, linear hydroengine). The hydraulic circuit was represented by an actuator having the following inputs: sudden excitement (i.e. value of the voltage signal on the controlling valve – this signal corresponds with the steering wheel angle) and value of force on the front axle controlling rod (calculated from the force developed on the front axle by means of the subsystem simulating the vehicle's operation).

### 2.2. Steering System

The subsystem contains a simplified kinematics of the front axle steering system and converts the value of the hydroengine piston rod extension into the front axle wheel angle.

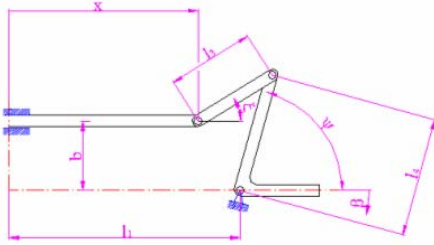

### 2.3. Vehicle Model – (See [4], [6])

The subsystem was used to simulate vehicle's cornering (a curved trajectory in general). To solve the vehicle's manoeuvrability and stability, a two-wheeled, plane dynamic model of the vehicle is used which is practical and beneficial because of its simplicity but at the same time also accuracy. The front wheel angle represented the input in the vehicle model.

### 3. Results of Simulation

The input values were selected with respect to their application in a passenger car. Vehicle data were compiled from VW Golf and Škoda Fabia documentation [8], [10] and [11]. For the hydraulic circuit the values were selected in accordance with the components supplied for the Steer-by-Wire testing stand.

This model can be used for a mathematical simulation of a complex dynamic system. To illustrate this with examples, an excitation of the system by means of an input voltage signal on a proportional valve was chosen. The results of the simulation are shown in the following pictures. In addition, excitation by means of a side wind applied to a car could be used.

The following graphs show the response of the system to a sudden change.

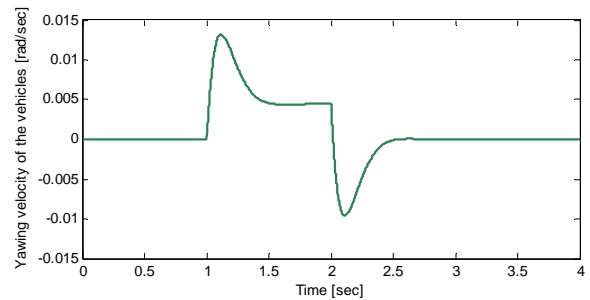
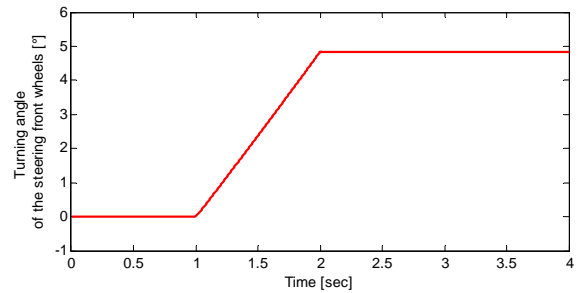
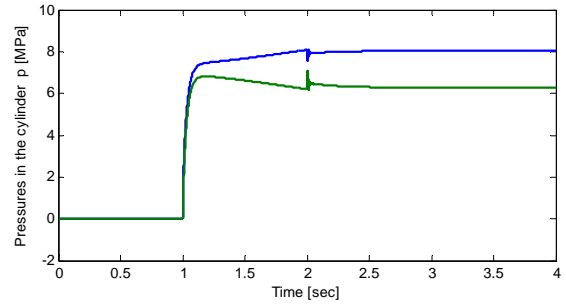
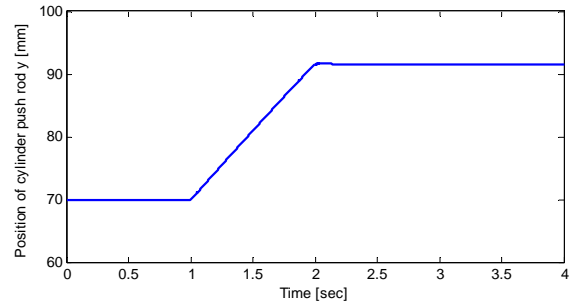
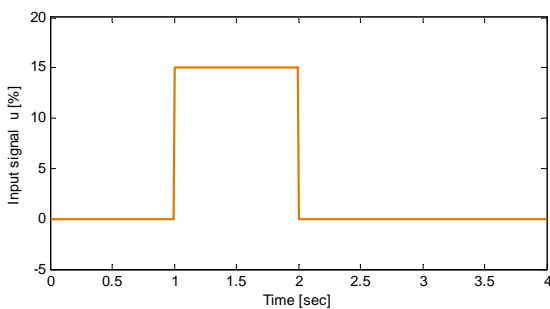
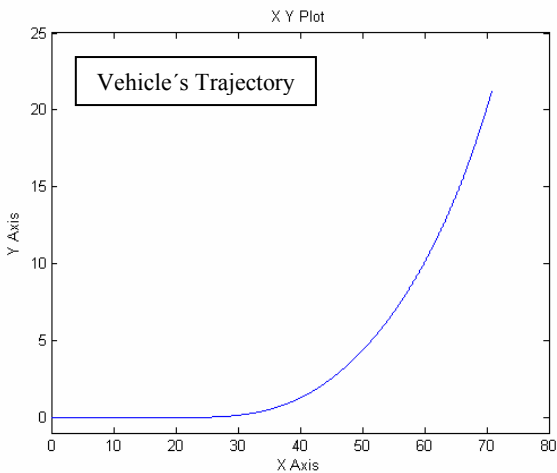

### 4. Conclusion

The project is focused on research of properties of a vehicle with an active directional control. The testing stand design enables to determine responses and behaviour of the system including tyres. The testing equipment benefits from its variability for both front and rear axle testing. The four wheel steering system (4WS) is even more frequently in the limelight as far as the vehicle's directional control is concerned (e.g. – a Renault's innovation, Renault Laguna GT).



SYSTEME ACTIVE DRIVE  
ACTIVE DRIVE SYSTEM

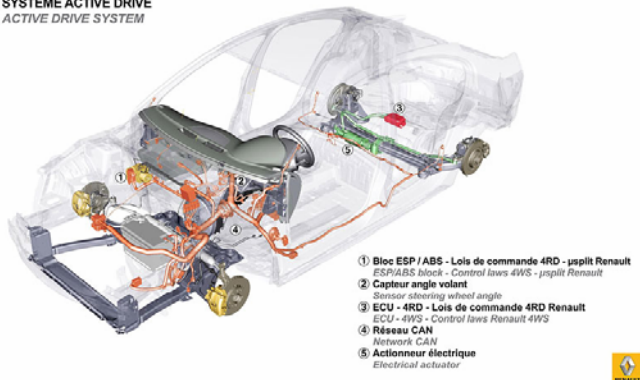

Fig.: 4WS system – Renault Laguna GT [12].

The mathematical model uses more variables (constants) which significantly impact the calculation itself (vehicle's behaviour during vehicle's maneuvering). Further steps should include verification of the mathematical model with data measured at the „steer-by-wire“ test stand. This model could also be used to optimize the vehicle's steering axles.

## 5. References

- [1] PAUL YIH - JIHAN RYU - J. CHRISTIAN GERDES: Vehicle handling modification via steer-by-wire, Dynamic Design Lab, Stanford University, 2003
- [2] <http://news.auto.cz/technika/by-wire-v-citronu-c5.html>
- [3] 15th Aachen Colloquium "Automobile and Engine Technology", October 2006
- [4] BRABEC, P. – VOŽENÍLEK, R.: Jednostopý a dvoustopý model vozidla. In: XXVIII. SEMINÁŘ KATEDER A INSTITUTŮ TRANSPORTNÍCH, STAVEBNÍCH, ÚPRAVÁRENSKÝCH A ZEMĚDĚLSKÝCH STROJŮ, DOPRAVNÍCH FAKULT A KATEDER. Str. 10 + CD. VŠB – TU OSTRAVA, Ostrava 2002. ISBN 80-248-0155-8.
- [5] BRABEC, P., HO, H., H., MALÝ, M., VOŽENÍLEK, R.: Model hnacího ústrojí s hydrokoly. In: XXIX. seminář kateder dopravnej a manipulačnej techniky.s. 50 – 56. TU vo Zvolene. Zvolen 2003. ISBN 80-228-1266-8.
- [6] BRABEC, P. – HO, H. H. – VOŽENÍLEK, R.: Simulace průjezdu vozidla zatáčkou. ZPRÁVA SM462/2003. TU v Liberci, Liberec 2003.
- [7] BRABEC, P. – MALÝ, M. - VOŽENÍLEK, R.: Automobil a boční vítr. In: XXX. seminář kateder a inštitútov TRANSPORTNÝCH, STAVEBNÝCH, ÚPRAVARENSKÝCH A POĽNOHOSPODÁRSKÝCH STROJOV. CD. Technická univerzita v Košiciach, Strojnícka fakulta, Ústav konštrukcie strojov a zariadení, Herľany 2004. ISBN 80-8073-164-0. LN00B073.
- [8] LAUMANN, N.: Integrale Reglerstruktur zur effektiven Abstimmung von Fahrdynamiksystemen, Institut für Kraftfahrwesen Aachen der RWTH Aachen, ISBN 978-3-925194-90-0

- [9] RASTE, T - SEMMLER, S - RIETH, E.: Global Chassis Control Emphasizing on Rest Wheel Steering, Continental Automotive Systems, Frankfurt
- [10] Poklady firmy Škoda Auto
- [11] [www.volkswagen.cz](http://www.volkswagen.cz)
- [12] [www.auto.cz](http://www.auto.cz)

*This paper has been developed with the support of the Ministry of Education, Youth and Physical Training, as the project MSM 46 74788501.*